

TECcad[©] HELP

TE Coolers list

- 1MC04-004-05
- 1MC04-004-08
- 1MC04-004-10
- 1MC04-004-12

Search for desirable TE Cooler

Parameters	Value
Delta Temperature [K]	0
Heat to pump at cold side [W]	0
TEC current available [A]	0
TEC voltage available [V]	0
Cold footprint area [mm x mm]	0x0

Graphs showing performance curves for different TE coolers.

Diagram showing a TE cooler configuration with parameters: T_{hot} , T_{cold} , Q_{cool} , I_{TEC} , V_{TEC} , P_{TEC} .

Simple Channel: Total T1, T2

Thermoelectric interface: Total T1, T2

Material properties: N_{type} , L_{length} , S_{cross} , $\kappa_{thermal}$

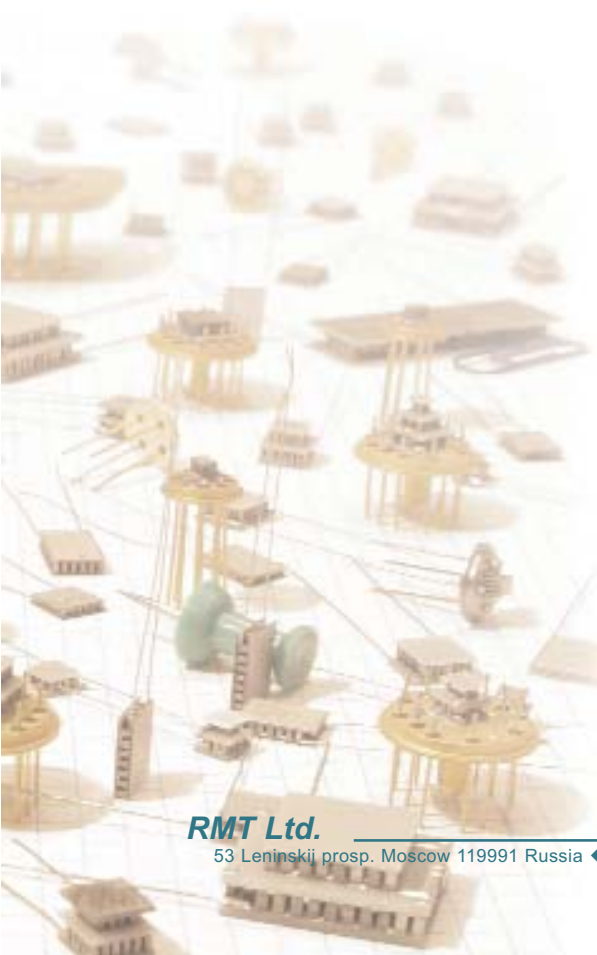

Moscow - 2007

Contents

- 1. Foreword to TECcad3
- 2. TECcad Mathematical Core4
- 3. TECcad Databases4
 - 3.1 TE Modules Database4
 - 3.2 TE Materials Library4
 - 3.3 Materials Database4
 - 3.4 Packages Database4
 - 3.5 Gas Properties Library4
- 4. TECcad Main Window5
 - 4.1 Main Menu5
 - 4.2 TE Modules Selection Field5
 - 4.3 Control Panel6
 - 4.4 Performance Plots Field7
 - 4.5 Results Field7
 - 4.6 Specification Field7
- 5. TECcad Sub-Programs8
 - 5.1 Optimal TE Module Design (OptTEC)8
 - 5.2 TE Module Construction8
 - 5.3 TE Module (TEC) Search9
 - 5.4 Standard Plots9
 - 5.5 Optimal Plots11
 - 5.6 Loads Modeling13
- 6. How to Work with TECcad14
- 7. Example of Solving a TE Problem by TECcad15
 - 7.1 Problem Statement15
 - 7.2 Solution15



TECcad Software

1. Foreword to TECcad

It is not a simple task to select a TE module that fits the need most optimally. It is also frequently necessary to give some operational characteristics of a TE module for a range of conditions and in the graphic form

To assist in it, the company RMT has developed the software TECcad.

TECcad is available in two version: **TECcad Lite** and **TECcad Pro** (Fig. 1) composed of several interrelated blocks unified by the mathematical core and data bases:

- ◆ **Optimal TE Module Estimation*** (OptTEC). The program allows estimating of approximate design of a TE module providing a given cooling capacity and temperature at a minimal power consumption possible.
- ◆ **TE module Designing*** (Construction). The program offers a tool to input a new TE module or modify an existing one in the TECcad database.

- ◆ **Search.** The searching program allows roughly selecting a TE module that meets initial requirements at 300 K, vacuum from the given list.
- ◆ **TE module Standard Plots.** The program allows calculating the plots that extend the specification of the selected TE module/TE system at given boundary conditions.
- ◆ **Optimal plots.** The program allows calculating the plots that describe optimal modes of the selected TE module at given boundary conditions.
- ◆ **Loads Modeling.** The program allows simulating a TE module (TE system) operation at a given active heat load allowing for thermal exchange with environment including thermal conduction channels at certain boundary conditions.

* – the functions available in the **Pro**-versions only.

TECcad Lite can be freely downloaded at the RMT site www.rmtltd.ru.

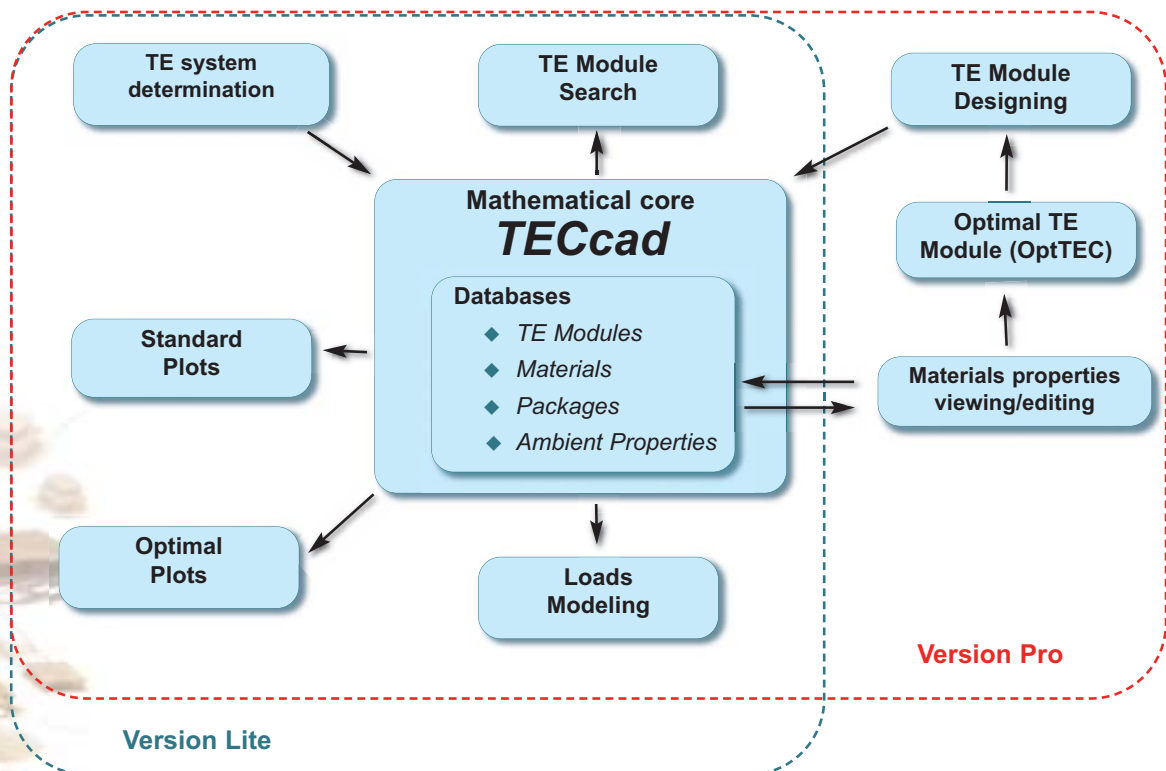

Figure 1. TECcad structure

2. TECcad Mathematical Core

Here we give major outlines on the TECcad mathematical core that a user should be aware of..

- 1) The TECcad calculations are carried out in the one-dimensional approach. It allows for the temperature distribution along the main heat flow direction: from the TE module cold side to the hot side. The calculations are based on the system of non-linear rate equations. The solution is obtained by the successive approximation method.
- 2) Along a pellet of one stage TE parameters are considered constant.
- 3) A TE parameter at a certain temperature value is considered the average of the corresponding values for p- and n-materials at this temperature. For each cascade we assume these parameters

constant values taken at the cascade hot side temperature . This method results in quite accurate estimations of the TE modules thermal parameters (ΔT , Q) and voltage U but some underestimation of the current I (up to 10% underestimation of I_{max} for single-stage TE modules, less underestimation for more cascaded ones).

- 4) All the layers of substrates (ceramics, metal junctions, solders) are taken into account as thermal resistances connected in series.
- 5) Pellets within cascades and cascades are connected in series.

3. TECcad Databases

3.1 TE Modules Database

The database of TE modules is a system of files. Each represents information on a certain TE module sufficient for calculations in TECcad: design and TE parameters as well as specification. The TECcad Lite default database is RMT complete TE modules bank.

Editing a TE module and adding/deleting one is possible by the program Construction*.

3.2 TE Materials Library

The database contains temperature dependences of p- and n-type correlated TE materials parameters: the Seebeck coefficient, electrical conductivity and thermal conductivity. This information is stored in the form of experimental points and polynomial coefficients.

The data and polynomials can be edited*.

The TECcad Lite involves two fixed standard p- and n-type TE materials.

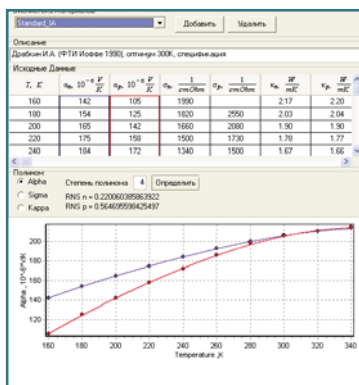

3.3 Materials Database

The database contains materials and their thermal and electrical properties involved in TECcad calculations. These are: density, thermal conductivity, specific heat, electrical conductivity.

3.4 Packages Database

Here are the design features and geometry of the major packages applied in TE sub-mounts. Packages materials are selected from the materials database.

3.5 Gas Properties Library

This database contains temperature dependences of the properties of such gases as dry air, argon, xenon. These are default gases used in TECcad Pro and the only ones offered by TECcad Lite. These properties are involved in the estimation of convection and thermal conductance through the gas environment and include density, thermal conductivity, specific heat and kinematic viscosity.

This information is stored in the form of experimental points and polynomial coefficients.

The data and polynomials can be edited*.

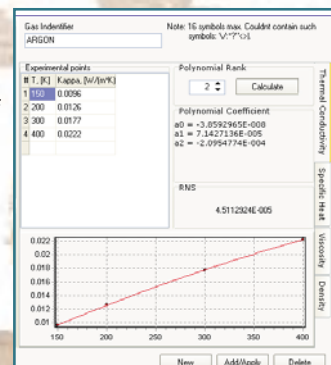

* – functions available in the Pro-versions only.

4. TECcad Main Window

In Fig. 4.1 the main TECcad window is given.

The main window has several functional fields:

- ◆ Main menu;
- ◆ TE modules selection field¹⁾;
- ◆ Control panel;
- ◆ Performance Plots field;
- ◆ Results field;
- ◆ TE module specification filed.

1) - in TECcad-Pro it is popped up with the command Menu / File.

4.1 Main Menu

There are four items in the menu:

- ◆ File;
- ◆ Edit*;
- ◆ Window*;
- ◆ Help.

File allows creating, opening*/closing* a file of the TE modules database, saving* it, opening* TE modules search filed, printing calculated results.

Edit* allows editing TE modules parameters with the help of the software Construction*.

Window* allows defining the directory TE modules search should be from, as wellas looking through and editing the materials properties databases (see Sec. 3 of this Help).

Help contains the TECcad description in Russian and English.

4.2 TE Modules Selection Field

It contains two sub-fields:

- 1) TE modules list from the database;
- 2) TE modules search - the field to fill in necessary parameters for searching a TE module.

A TE module selection is possible manually or by the search software - see Sec. 5.3.

The TE modules selection field is fixed in TECcad Lite and is opened by Menu / File in TECcad Pro.

Having selected a TE module to simulate, please either click th button "Draw Plot" or double-click the TE module in the list. By default the preliminary calculation is carried out for the conditions of 300 K, in vacuum, no heat exchangers, heat loads or channels.

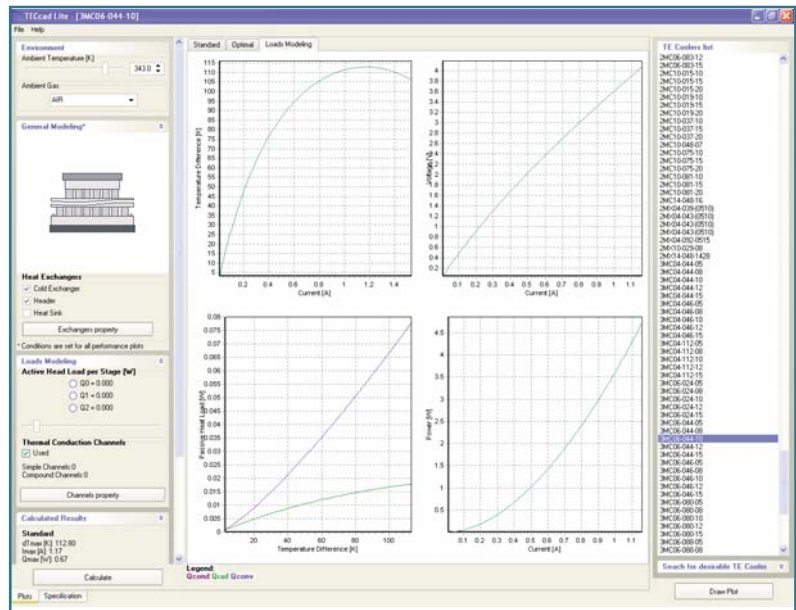

Figure 4.1 TECcad main window

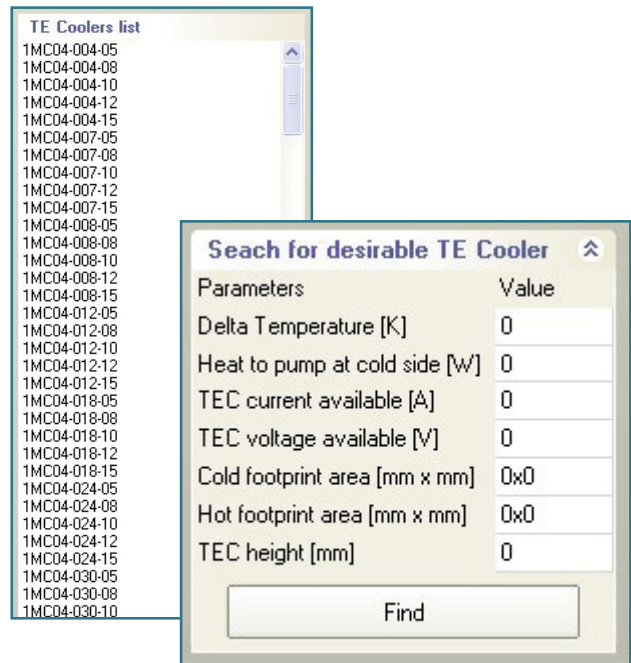

Figure 4.2.1 TE modules list and serch parameters

4.3 Control Panel

The control panel allows setting boundary conditions for a TE module simulating. The conditions are divided in three groups: **Environment**, **General modeling** and **Loads modeling**.

The **Environment** and **General modeling** conditions embrace those of ambient surrounding and heat exchangers. They are observed in all the calculational modes.

1. Environment:

- ◆ Ambient temperature;

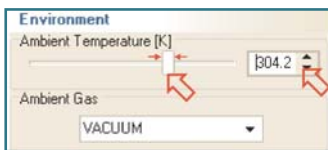

- ◆ Environment (air, argon, xenon, vacuum)

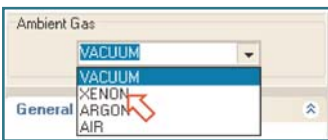

Attention: Thermal emission (radiation) is always taken into account in the software TECcad Lite. The version TECcad Pro allows eliminating the radiation from the calculation.

2. General Modeling - Heat exchangers:



- ◆ Cold heat exchanger;
- ◆ Header;
- ◆ Heat sink.

To set the heat exchanger material properties and its geometry use the button “Exchangers property”.

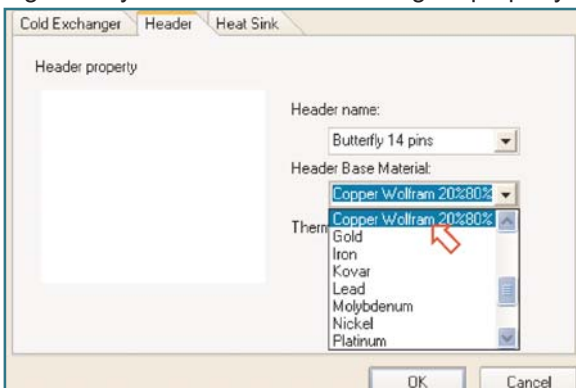

For a cold heat exchanger and a header it is possible to set thermal resistance manually. The value of thermal resistance is calculated automatically for a cold heat exchanger - parallelepiped with known sizes and for a header chosen from a database, if materials are ceratin. The thermal resistance of a hot heat exchanger should be set manually.

Additional heat load conditions (active and thermal conduction ones) are observed only in **Loads modeling**:

3. Loads Modeling:

- ◆ Active heat load:



The active heat load is constant in all the TE module temperature points. For multistage TE modules it can be set per cascade.

- ◆ Thermal conduction heat load:

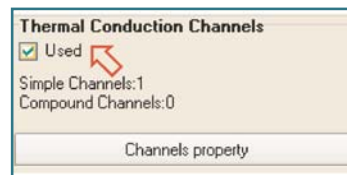

TECcad allows calculating passive heat fluxes flowing to the TE module cold side by thermal conduction channels of various complexity. There are two kinds of such channels in TECcad::

- ◆ Simple channel - a channel connecting two temperature points.
- ◆ Compound channel - a channel connecting three temperature points.

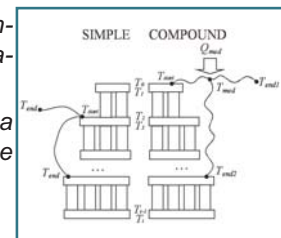

To set the thermal conduction channel it is necessary to click the button “Channels property”. Select temperature points and set thermal conductivity and geometry of the channel or its known thermal resistance.

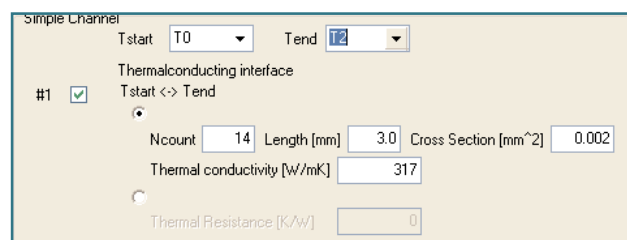

4.4 Performance Plots Field

Here are three plotting fields:

- ◆ Standard Plots;
- ◆ Optimal Plots;
- ◆ Loads modeling.

The plots are captured synchronously, in correspondence with the conditions given in the control panel (Sec. 4.3).

The *General modeling* conditions are observed in all the calculational modes, in all the three plots. The *Loads modeling* conditions observed only in the Loads modeling performance plots.

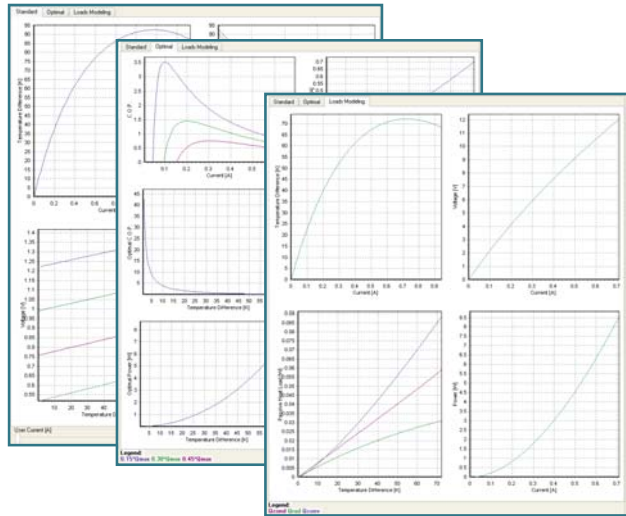

4.5 Results Field

The Results field contains numerical data calculated in the Standard Performance and Loads Modeling (see Sec. 5.4, 5.6):

1. Standard Plots Results:

- ◆ Maximum temperature difference ΔT_{max} ;
- ◆ Maximum current I_{max} ;
- ◆ Maximum cooling capacity Q_{max} ;
- ◆ Maximum voltage U_{max} ;
- ◆ TE module resistance R ;
- ◆ TE module time constant τ .

2. Loads Modeling Results:

- ◆ Maximum temperature difference ΔT_{max} ;
- ◆ Maximum current I_{max} ;
- ◆ Maximum voltage U_{max} ;
- ◆ Temperature distribution per cascade at $I...I_{max}$.

Calculated Results

Standard

dTmax [K]: 102.81
 Imax [A]: 1.76
 Qmax [W]: 0.75
 Umax [V]: 2.09
 R [Ohm]: 0.93
 Time Const [sec]: 4.96

Loads Modeling

dTmax [K]: 102.81
 Imax [A]: 1.76
 Umax [V]: 2.08

Temperatures per stages @ I = 1.22
 T0= 203.1; T1= 203.1; T2= 245.7; T3= 245.3; T4= 301.0; T5= 300.0;

Specification

Type	Parameters								
	ΔT_{max} [K]	Q_{max} [W]	I_{max} [A]	U_{max} [V]	R [Ohm]	Gold Size [mm ²]	Hot Size [mm ²]	Height [mm]	
3MC6-046-02	116	0.49	1.00	3.66	18.94	2.94	2.8x4.8	18.8x8.8	6.87

Tau=300.0 [s], YAC10FM

Stage 1
 Top/Bottom ceramic material: Ceramic AD03 - 100% / Ceramic AD03 - 100%
 Pellets material: Shadur_LAG3 - 100%
 Pellets geometry [mm²]: 0.6 x 0.6 x 1.2
 Pellets Number: 8

Stage 2
 Top/Bottom ceramic material: Ceramic AD03 - 100% / Ceramic AD03 - 100%
 Pellets material: Shadur_LAG3 - 100%
 Pellets geometry [mm²]: 0.6 x 0.6 x 1.2
 Pellets Number: 22

Stage 3
 Top/Bottom ceramic material: Ceramic AD03 - 100% / Ceramic AD03 - 100%
 Pellets material: Shadur_LAG3 - 100%
 Pellets geometry [mm²]: 0.6 x 0.6 x 1.2
 Pellets Number: 62
 Solder: Solder Sn-97% Pb-3% (200)

4.6 Specification Field

The basic data on a TE module, its outlines, simulated results and corresponding conditions are given in the field "Specification":

- ◆ Standard results;
- ◆ Environment and General Modeling conditions (see Sec. 4.3);
- ◆ TE module geometry;
- ◆ TE module draft outlines;
- ◆ Ceramics sizes and materials (per stage);
- ◆ Pellets sizes and materials (per stage);
- ◆ Pellets number (per stage).

5. TECcad Sub-Programs

5.1 Optimal TE Module Design (OptTEC)*

The program OptTEC implements the algorithm of modelling an optimal TE module providing The following parameters are to be preset:

- ◆ n - cascades number;
- ◆ T_{cold}, T_{hot} - TE module cold and hot sides temperature;
- ◆ TE materials per stage (see TE materials library 7.3.2);
- ◆ Q_{cold} - heat load on the TE module; if necessary additional heat load per stage;
- ◆ Pellets width;
- ◆ Height of cold stage pellets.

It is possible to take into account a coefficient of TE materials efficiency less than unity. It may be used to simulate thermal losses on the substrates not allowed for here.

Temperature dependences of materials are taken from the TE materials library.

This program consists of two blocks calculating:

- ◆ Optimal temperature sequence on the cascades;
- ◆ Approximate module design: pellets number and geometry per cascade.

The latest optimal TE module design is stored in the file lastopt.opt. For its adaptation and storage into the TECcad TE modules database the software Construction is used.

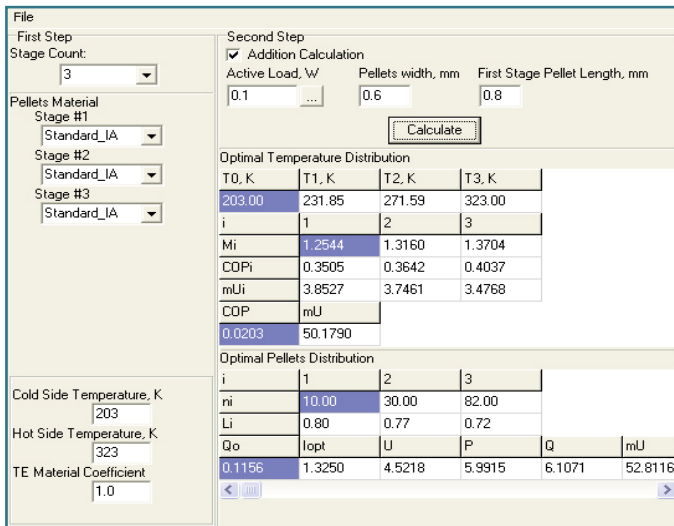

Figure 5.1.1 OptTEC window

Thus the OptTEC software allows obtaining the following results for the optimal TE module:

- ◆ Optimal temperature values per stage T_{opti}
- ◆ Pellets number per stage N_i ;
- ◆ Pellets geometry per stage;
- ◆ TE module optimal current and voltage I_{opt}, U_{opt} ;
- ◆ Coefficients of Performance per stage COP_i ; TE module COP.
- ◆ Heating coefficients per stage μ_i ; TE module μ and heat to be rejected Q_{hot}

In Fig. 5.1.1 the OptTEC window is given.

5.2 TE Module Construction*

For creating a new TE module in the TECcad database the program Construction is used.

The program allows either inputting the entire description of a TE module manually, or importing the information on a TE module available in the resulted OptTEC file, or just visualizing the TE module design and TE materials required, if the module already exists in the database.

After filling in (adding, if necessary) all the required data on a TE module it is possible to start mathematical simulation of the module with the help of the other sub-programs.

* - functions available in the Pro-versions only.



Рисунок 4.2.1 Основное окно программы Construction

5.3 TE Module (TEC) Search

The TE modules search is based on the TE and geometrical parameters commonly used by customers to specify their need. The parameters to specify are referred to 300 K, vacuum. These parameters system can be either complete or incomplete.

The complete system of a TE module parameters required can be divided into three groups (Table 5.3.1).

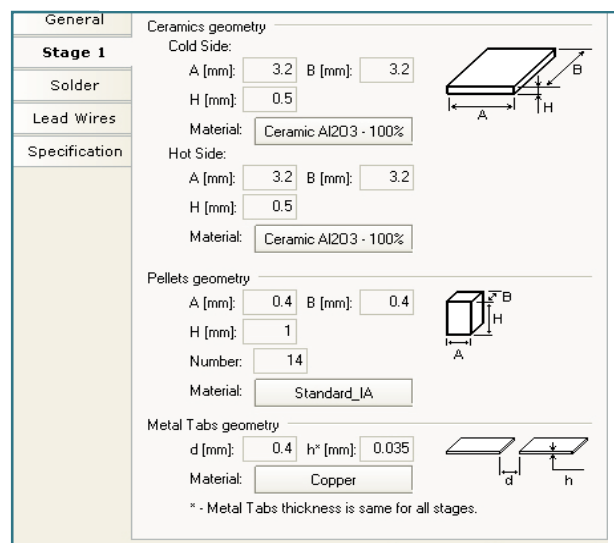
With the help of this program a TE module search from the database is carried out by the modules specification analysis.

The criteria for a TE module selection are analyzed independently.

Suppose the needed TE module parameters are: delta-temperature ΔT , cooling capacity Q, available electric current and voltage I, U, the sufficient cold side axb, the hot side not exceeding cxd and the TE module

height not exceeding h. The TE module is selected from the data base if its specifications ΔT_{max} , Q_{max} , I_{max} , U_{max} , AxB, CxD, H meet the requirements of Table 5.3.2.

If the system of the specified parameters is incomplete, a nonessential parameter is set zero by default. In this case a TE module with any value of this parameter fits the search.

It is important to mention that the main role of the TEC search is to make narrower a circle of TE modules under study. To determine a final choice it is necessary to use the other subprograms.

Table 5.3.1. Complete system of TE module parameters to be specified in TEC search

Thermal parameters:	Required temperature difference ΔT , K
	Required cooling capacity Q, W
Electrical parameters:	Available electric current I, A
	Available electric voltage U, V
Geometric parameters:	Cold side dimensions axb, mm ²
	Hot side dimensions cxd, mm ²
	Height h, mm

Table 5.3.2. TEC Search criteria for TE module selection

Thermal parameters:	$\Delta T_{max} > \Delta T$
	$Q_{max} > Q$
Electrical parameters:	$I_{max}/2 < I$
	$U_{max}/2 < U$
*One half is modeling optimal use of TE module	
Geometrical parameters:	$AxB >= axb$
	$CxD = < cxd$
	$H = < h$

5.4 Standard Plots

For any TE module selected from the database or designed by the software Construction* Standard Performance Plots (the Standard Plots) can be built.

The calculations are carried out supposing the heat rejection is ideal: the TE module/TE system hot side temperature is equal to the ambient temperature $T_{hot} = T_a$.

The value T_{hot} can be settled within the range 100... 400 K.

Calculations can be done for vacuum and gases: dry air, argon and xenon (gas is taken into account both by a passive heat load on cascades and additional heat flows between the pellets). Radiation is only allowed for in the passive heat load.

By default the calculations are done for vacuum at $T_{hot} = 300$ K. These are TE module/TE sub-mount standard specification performance plots

Exemplary Standard Plots for a single-stage TE module at the hot side temperature $T_{hot}=300$ K, in vacuum, are given in Fig. 5.4.1 - 5.4.4.

- ◆ $\Delta T(I)$. Temperature difference versus current $\Delta T(I)$ at the cooling capacity $Q=0$. The function $\Delta T(I)$ has maximum at the current $I=I_{max}$. The corresponding temperature difference is $\Delta T=\Delta T_{max}$. The plot helps to obtain I_{max} and ΔT_{max} of a TE module.
- ◆ $\Delta T(Q)$. Temperature difference versus cooling capacity at electric current values $I=(I_{max}, 0.8I_{max}, 0.6I_{max}, 0.4I_{max})$. At the current $I=I_{max}$ and temperature difference $\Delta T=0$ cooling capacity is at maximum: $Q=Q_{max}$. If any two of the three values ΔT , Q , I are known, the plot assists in estimating the third one.
- ◆ $U(\Delta T)$. Voltage versus temperature difference at electric current values $I=(I_{max}, 0.8I_{max}, 0.6I_{max}, 0.4I_{max})$. At $I=I_{max}$ and $\Delta T=\Delta T_{max}$ the voltage equals $U=U_{max}$. The plot assists in estimating a TE module voltage if the current I and delta-temperature ΔT are known.
- ◆ $COP(\Delta T)$. Coefficient of Performance (see Chapter 3, Sec. 3.4) versus temperature difference at electric current values $I=(I_{max}, 0.8I_{max}, 0.6I_{max}, 0.4I_{max})$. The plot helps to conclude whether a TE module power consumption at the operational I , Q and ΔT is economical enough.

For a TE module mounted on a header the plot $COP(\Delta T)$ is changed by the plot $Q_{hot}(\Delta T)$:

- ◆ $Q_{hot}(\Delta T)$. The heat Q_{hot} to be rejected from the TE sub-mount hot side versus its temperature difference ΔT at the electric current $I=(1, 0.8, 0.6, 0.4)I_{max}$. The plot assists in estimating the heat to be sunk from the sub-mount at the needed I and ΔT . (Fig. 5.4.4).

It is possible to build the curves $\Delta T(Q)$, $U(\Delta T)$, $COP(\Delta T)$, $Q_{hot}(\Delta T)$ at any electric current up to I_{max} .

This subprogram allows calculating the following TE module parameters: ΔT_{max} , I_{max} , Q_{max} , U_{max} , as well as TE module electrical resistance R and its time constant τ at the given temperature T_{hot} . At $T_{hot}=300$ K in vacuum these values are the TE module standard specification.

ATTENTION:

If for a cold exchanger at the value I_{max} , calculated for a no exchanger case, the temperature difference is negative, there pops up a warning: **Required heat load cannot be pumped.**

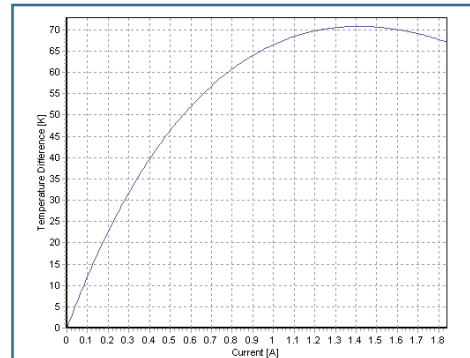

Figure 5.4.1. $\Delta T(I)$ at $Q=0$

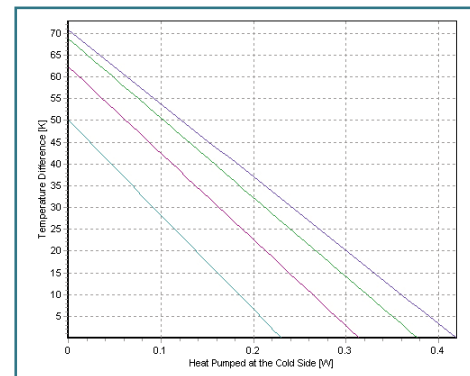

Figure 5.4.2. $\Delta T(Q)$ at $I=(1.0, 0.8, 0.6, 0.4) I_{max}$

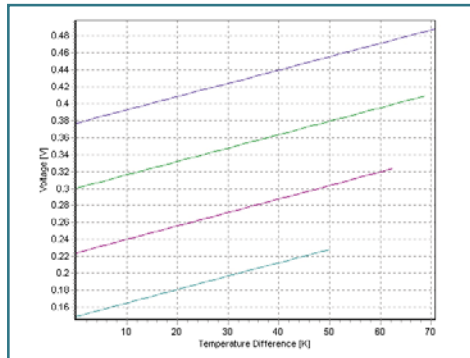

Figure 5.4.3. $U(\Delta T)$ at $I=(1.0, 0.8, 0.6, 0.4) I_{max}$

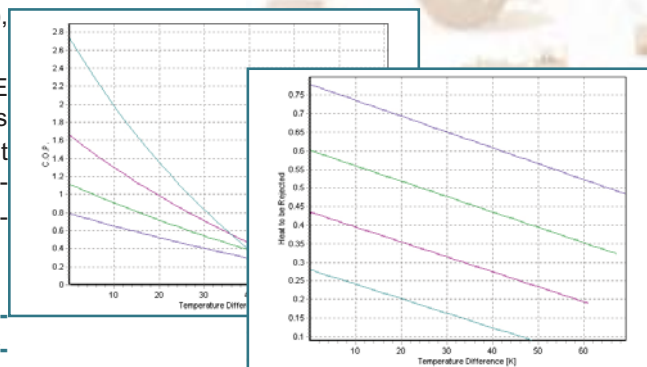

Figure 5.4.4 $COP(\Delta T)$ and $Q_{hot}(\Delta T)$ at $I=(1.0, 0.8, 0.6, 0.4) I_{max}$

5.5 Optimal Plots

The Standard Plots imply that the same temperature difference ΔT can be achieved at different parameters of the TE module: at different cooling capacity and power consumption, i.e. operating at different COP.

For any value of the TE module temperature difference ΔT taken within the range $0 \dots \Delta T_{max}$ there can be found such a combination of the current I , voltage U and cooling capacity Q , that the COP is at maximum. The operational mode for a certain ΔT at maximum COP is called optimal for this ΔT .

In the TECcad software this mode is characterized by the following plots (at $T_{hot}=300$ K, vacuum):

- ◆ $COP(I)$ at several values of ΔT : $(0.15, 0.30, 0.45)\Delta T_{max}$ - see Fig. 7.4.6.1. It demonstrates the interception of the maximum COP_{opt} for a given ΔT at an optimal current I_{opt} . The result of a study of $COP(I)$ for are the curves $COP_{opt}(\Delta T)$ and $I_{opt}(\Delta T)$ for ΔT up to ΔT_{max} (Fig. 7.4.6.2 and 7.4.6.3).
- ◆ $COP_{opt}(\Delta T)$. It is the ordinate of the maximum values of $COP(I)$ - see the plot in Fig. 7.4.6.2.
- ◆ $I_{opt}(\Delta T)$. It is the abscissa of the maximum values of $COP(I)$ (see Fig. 7.4.6.3).
- ◆ $Q_{opt}(\Delta T)$. The value I_{opt} for each ΔT determines the optimal cooling capacity Q_{opt} . The curve shows that the optimal cooling capacity of a TE module is at maximum at ΔT and I about half of their maximums. To make it more comprehensive below we give an example of the optimal plot $Q_{opt}(\Delta T)$ and the standard plot $Q(\Delta T)$ at I_{max} .

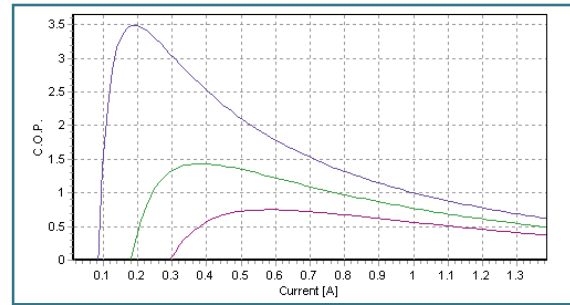

Figure 5.5.1. $COP(I)$ at $\Delta T=(0.15, 0.30, 0.45)\Delta T_{max}$

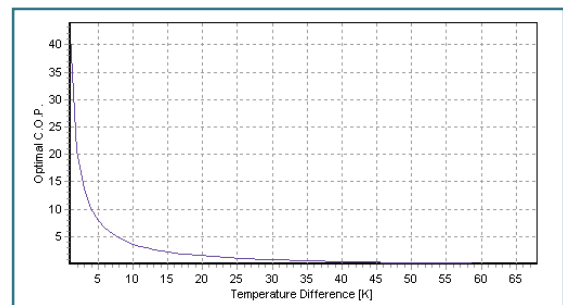

Figure 5.5.2. $COP_{opt}(\Delta T)$

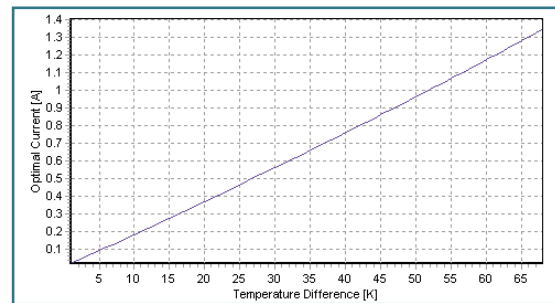
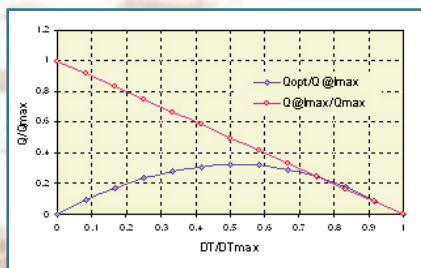

Figure 5.5.3. $I_{opt}(\Delta T)$



Optimal plot $Q_{opt}(\Delta T)$ and the standard plot $Q(\Delta T)$ at I_{max}

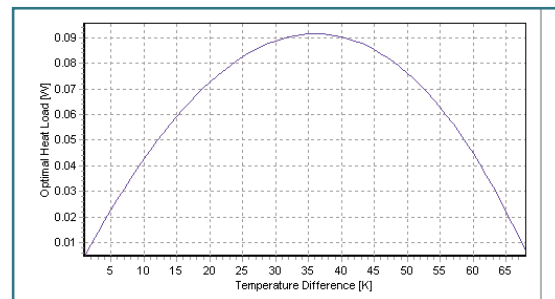

Figure 5.5.4. $Q_{opt}(\Delta T)$

- ◆ $U_{opt}(\Delta T)$. It presents the dependence of the voltage corresponding to I_{opt} on the temperature difference ΔT .
- ◆ $P_{opt}(\Delta T)$. It offers the dependence of the voltage corresponding to I_{opt} on the temperature difference ΔT . It gives the minimal possible power consumption P at various ΔT .

Similarly to the Standard Plots (see Sec.5.4), the calculations are carried out supposing the heat sink is ideal: the TE module hot side temperature is equal to the ambient temperature $T_{hot}=T_a$.

The value T_{hot} can be settled within the range 100...400 K. By default the plots are calculated for vacuum at $T_{hot}=300$ K.

Calculations can be done for vacuum and gases: dry air, argon and xenon. The environment and radiation are taken into consideration the same way as for standard plots (see Sec. 5.4).

If the operational parameters of a TE module are known, the Optimal plots helps to answer whether this operational mode close to the optimal one. If the COP value is too low it is necessary either to correct the mode parameters or to select another TE module.

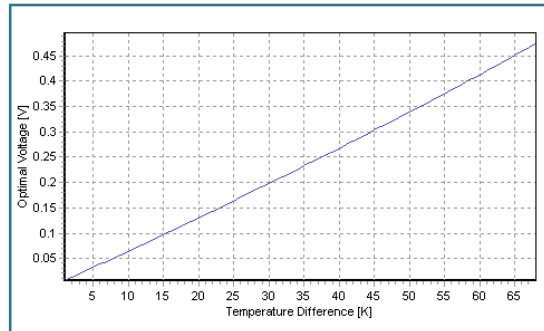

Figure 5.5.5. $U_{opt}(\Delta T)$

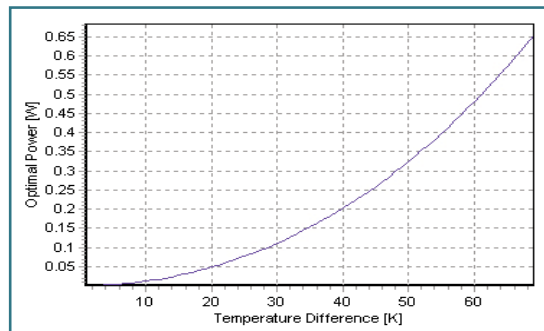

Figure 5.5.6. $P_{opt}(\Delta T)$



5.6 Loads Modeling

It is often necessary to define a TE module (TE system) operational parameters for a full heat to be pumped Q . For this purpose the TECcad software offers the subprogram **Loads Modeling**.

The full heat load on a TE module comprises the active heat load Q_a , which is to be pumped from the cooled object directly, and the passive heat load Q_{pas} that arises from accompanying processes of the heat interchange with the ambient by convection, thermal radiation and conduction.

This subprogram enables one to set all the necessary conditions to estimate $Q_{pas}(\Delta T)$ for a TE module with an object mounted on its cold surface.

Besides the radiation and convection heat load, one can describe active and thermal conduction heat load in their field **Loads modeling** of the Control Panel (Sec. 4.3). For a multistage TE module it is possible to set additional heat loads per stage.

ATTENTION:

If the summed active heat load Q exceeds 90% of the maximum cooling capacity Q_{max} of the TE module at $Q_a=0$, there pops up a warning: *Required heat load cannot be pumped.*

Loads modeling plots comprise:

- ◆ $\Delta T(I)$. The TE module/system temperature difference ΔT versus the electric current I at the needed full heat load (TE module cooling capacity) Q . The plot helps to define either the value ΔT at the TE module operational Q and I or the current I to provide the required ΔT and Q .
- ◆ $U(I)$. The TE module volt-ampere characteristic at the full heat load Q .
- ◆ $P(I)$. The TE module power consumption versus electric current.
- ◆ $Q_{pas}(\Delta T)$. The TE module/system passive heat load (radiation, convection, thermal conduction) versus temperature difference ΔT .

In Fig. 5.6.1-5.6.4 an example of the Loads modeling plots for the TE module 1MC04-004-08 at the active heat load $Q=60$ mW is given. TE module is to operate in the dry air. There are 10 copper leading wires connected to the object on the cold side, diameter $25 \mu\text{m}$ (cross-section 0.0005 mm^2). The TE module hot side is kept at the temperature $T_{hot}=300$ K.

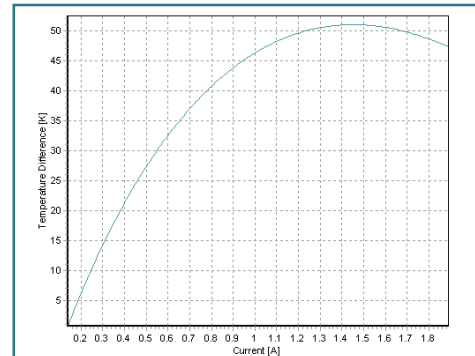

Figure 5.6.1. $\Delta T(I)$ at a the summed heat load Q

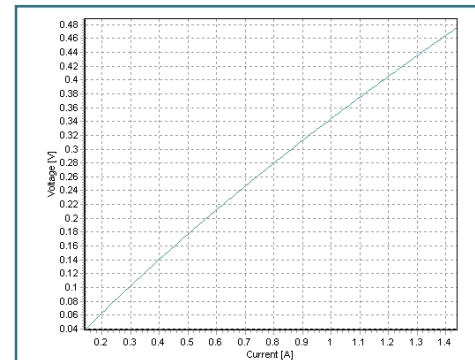

Figure 5.6.2. $U(I)$ at a the summed heat load Q

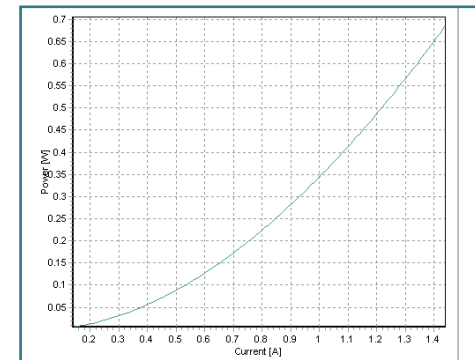

Figure 5.6.3. $P(I)$ at a the summed heat load Q

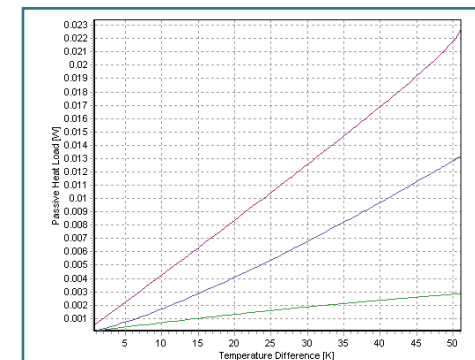

Figure 5.6.4. Passive heat loads of different nature: radiation, convection, thermal conduction

The hot surface temperature T_{hot} can be chosen within the range 100...400 K.

By default the plots are calculated for vacuum. Calculations can also be done for gases: dry air, argon and xenon.

The environment and radiation are taken into consideration the same way as for standard plots, taking into account geometry and emissivity of the object mounted on the TE module cold side.

The software interface allows detailed describing thermal conductance channels of different complexity - see Fig. 5.6.5. The Simple channel connects two temperature points. The Compound one three temperature points (it is realized with a certain intermediate temperature point T_{med}); at the point T_{med} an additional heat load can also be allowed for Q_{med} .

ATTENTION:

If for thermal conduction channels at the value I_{max} , calculated for a no channel case, the temperature difference is negative, there pops up a warning: *Required heat load cannot be pumped.*

Fig. 5.6.5. Window for setting conditions for the simple and compound thermal conduction channels

The screenshot shows a software window for configuring thermal conduction channels. It is divided into two main sections: 'Simple Channel' and 'Compound Channel'.

Simple Channel:

- Temperature points: T_{start} (T0) and T_{end} (T2).
- Thermalconducting interface: $T_{start} \leftrightarrow T_{end}$.
- Channel 1 (#1): $N_{count} = 10$, $Length [mm] = 5.0$, $Cross Section [mm^2] = 0.0005$, $Thermal conductivity [W/mK] = 400$, $Thermal Resistance [K/W] = 0$.

Compound Channel:

- Temperature points: T_{start} (T0), T_{end1} (T2), and T_{end2} (T2).
- Thermalconducting interface: $T_{start} \leftrightarrow T_{med}$.
- Channel 1 (#2): $N_{count} = 20$, $Length [mm] = 5.0$, $Cross Section [mm^2] = 0.002$, $Thermal conductivity [W/mK] = 317$, $Thermal Resistance [K/W] = 0$.
- Channel 2: $T_{med} \leftrightarrow T_{end1}$. $N_{count} = 2$, $Length [mm] = 10.0$, $Cross Section [mm^2] = 0.0005$, $Thermal conductivity [W/mK] = 72$, $Thermal Resistance [K/W] = 0$.
- Channel 3: $T_{med} \leftrightarrow T_{end2}$. $N_{count} = 10$, $Length [mm] = 4.0$, $Cross Section [mm^2] = 0.001$, $Thermal conductivity [W/mK] = 400$, $Thermal Resistance [K/W] = 0$.
- Timed Active Heat Load: $Q_{med} [W] = 0.02$.

6. How to Work with TECcad

The procedure of working is as follows.

- 1) Open the TECcad.exe file. The main window will appear. It displays:
 - ◆ Control panel with the default standard conditions;
 - ◆ Performance plots and Results fields with an exemplary TE module simulated (in the Lite version*).
 - ◆ TE modules list with all the modules available in the data base (the Lite version*).
- 2) Choose a TE module in the TE modules selection field. In TECcad Pro use the command Menu / File.
- 3) If necessary, apply the Search window. Fill in the searching values and click "Find".
- 4) After choosing a module, either double click on it in the List or click on the button "Draw Plot".
- 5) Fill the conditions in the Control Panel Environment field.
- 6) Click on the button "Calculate".

7) Fill the conditions in the Control Panel **General Modeling** field.

8) Click on the button "Calculate".

9) Fill the conditions in the Control Panel **Loads Modeling** field.

10) Click on the button "Calculate".

11) If necessary, print the results. The following issues can be printed:

- ◆ Page 1: TE modules general information;
- ◆ Page 2: TE module specification and Standard Performance Plots;
- ◆ Page 3: Optimal Performance Plots;
- ◆ Page 4: Loads Modeling Performance Plots along with calculated data and conditions of active and passive heat loads.

12) Exit or close the program.

* – in the Pro-versions a TE module is simulated after opening its file from the data base. TE modules search is opened by the Menu/File.

7. Example of Solving a TE Problem by TECcad

7.1 Problem Statement

To select and simulate a TE module providing an optimal fit for the following requirements:

- 1) A TE module is intended for cooling and thermal stabilization of a detector. The active heat load is 3 mW. The photodetector temperature shall be no more than minus 30 °C.
- 2) The planar dimensions of the detector are 3x4 x 0.3 mm³ (silicon substrate). The TE module cold side can be slightly lesser than 3x4 mm².
- 3) The TE module shall be mounted on the header TO8 (6 pins) made of kovar.
- 4) The ambient is dry air.
- 5) The ambient temperature is 70 °C.
- 6) The detector is connected with the header pins by 4 wires: 2 golden and 2 platinum. The diameter is 0.05 mm, the length is 5 mm.
- 7) Passive heat loads estimations at $\Delta T=100$ K yield $Q_{pas}=115$ mW. Therefore, the full heat load equals approximately $Q=Q_a+Q_{pas}=118$ mW.

7.2 Solution

1. For a preliminary search we take the heat load round-off value 120 mW .

2. The necessary temperature difference is 100 K. The cooled surface is set as 2 mm x 4 mm. The header TO8 (6 pins) surface open for mounting is 8 mm x 8 mm, so the TE module hot side surface cannot exceed this value.

3. Items 1 и 2 taken into account, the subprogram TEC Search restricts the TE modules database list to the following ones:

2MC06-021-(08 ...15)

3MC06-024-(05 ...15)

4. Considering a temperature gradient along the header thickness, with the hot side temperature $T_{hot}=70^{\circ}C=343$ K, we analyze their parameters by the subprogram Optimal Plots for $\Delta T=100$ K.

Table 7.2.1. Optimal module results for $\Delta T=100$ K

TE module	Q_{opt} , mW	P_{opt} , mW
2MC06-021-08	0.12	2.5
2MC06-021-10	0.11	2.0
2MC06-021-12	0.09	1.7
2MC06-021-15	0.08	1.4
3MC06-044-05	0.21	3.9
3MC06-044-08	0.15	2.5
3MC06-044-10	0.12	2.0
3MC06-044-12	0.10	1.6
3MC06-044-15	0.08	1.4

We conclude that the most optimal TE modules with minimal power P consumption is the following:

3MC06-044-10 ($\Delta T=100^{\circ}$, $Q=0.12$ W, $P=2.0$ W)

5. The Standard specification on the module 3MC06-044-10 (at 300K, in vacuum, no header) are:

$\Delta T_{max} = 114.6$ K

$I_{max} = 1.18$ A

$Q_{max} = 0.58$ W

$U_{max} = 3.45$ V

$R = 2.36$ Ohm

$\tau = 9.37$ s

If necessary, the Standard Plots of the module are available.

The TE module is mounted on the header TO8 (6 pins). The sub-mount fits the nomenclature as TO806.3MC0604410. The header hot side is $T_{hot}=300$ K, the ambient is vacuum. Therefore we have the following figures:

$\Delta T_{max} = 111.9$ K

$I_{max} = 1.13$ A

$Q_{max} = 0.56$ Ohm

$U_{max} = 3.48$ V

The thermal resistance of the header (see Control panel/General Modeling/Heat exchangers):

$R_t = 2.09$ K/W

7. For calculating the TE sub-mount parameters in the operational mode we apply the subprogram Modelling.

The sub-mount hot side temperature should be again shifted to $70^{\circ}C=343$ K. Choose the environment - air.

The leading wires connecting the object to be cooled with the package are two Simple channels. The necessary thermal and geometrical data on them should be entered. The diameter is 0.05 mm relates to the cross-section ~ 0.002 mm².

In the field "Cold Exchanger" the geometry and emissivity of the object are to be inputted. For the preliminary estimation the emissivity can be assumed unity.

We set the active heat load 0.003 W.

The above data considered, the Modeling Loads Performance plots are built.

The simulation of the dependence Q_{pas} on ΔT yields the following results for $\Delta T=100$ K - see Table 7.2.2. The Loads Modeling Plots are given in Fig. 7.2.1, the operational parameters are in Table 7.2.3

Table 7.2.2. TECcad estimated passive heat loads at $\Delta T=100K$

Heat Load	Value, W
Active, Q_a	0.003
Along wires, Q_w	0.019
Convection, Q_{conv}	0.067
Radiation, Q_{rad}	0.022
Passive, $Q_{pas} = Q_w + Q_{conv} + Q_{rad}$	0.108
Summed, $Q = Q_a + Q_{pas}$	0.111

Table 7.2.3. Operational parameters of the sub-mount TO806.3MC0604410 at $\Delta T=100^\circ$

Sub-mount parameters TO806.3MC0604410	Value
R_t , K/W	2.09
T_{cold} , $^\circ C$	-30
ΔT , $^\circ$	100
I , A	0,9
U , V	3,3
P , W	2,97
Q_{hot} , w	3.08

We see that in the conditions stated above the TE sub-mount selected meets the requirements..

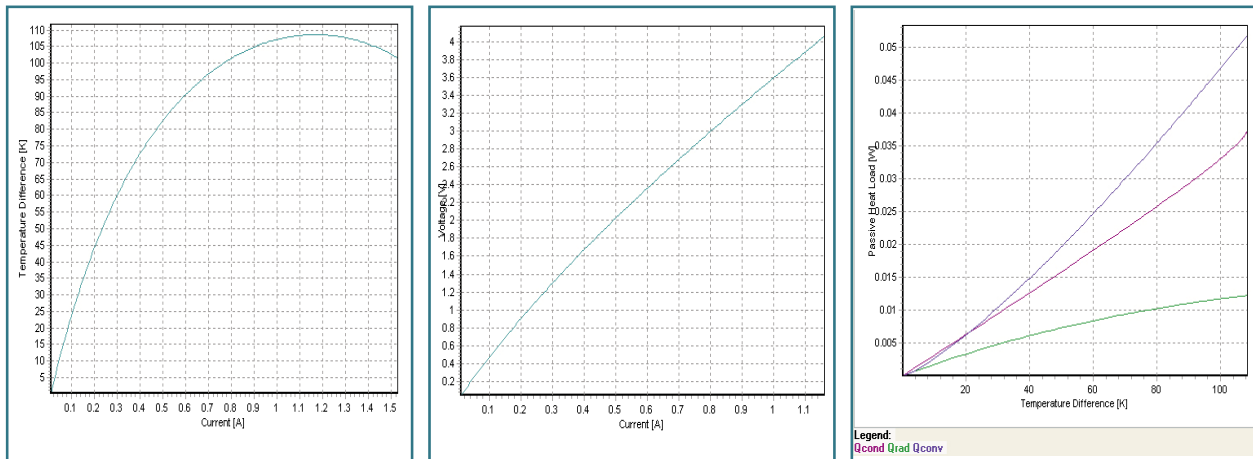
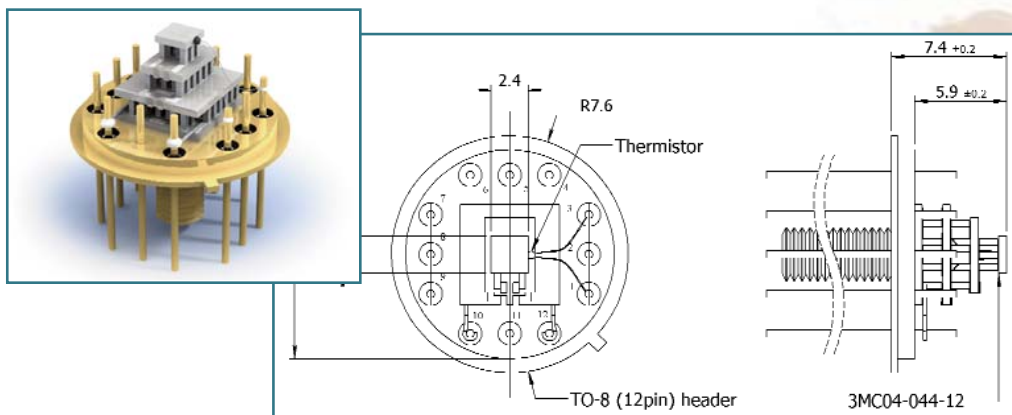

Figure 7.2.1. Loads Modeling Performance Plots $\Delta T(I)$ and $U(I)$ for TO806.3MC0604410 at the active heat load $Q=0.003$ W, passive heat loads taken in to account, $T_{hot}=343$ K



ATTENTION: The TECcad Lite version is available for free downloading at the company RMT site www.rmtltd.ru